



AMERICAN FLOOR PRODUCTS COMPANY, INC.

AFCO-USA

P.O. BOX 7055 • Gaithersburg, Maryland 20898 -7055 • 301-987-0490 • Fax 301-987-0422
 email: sales@afco-usa.com • Web Site: www.afco-usa.com

CUSTOMER P.O. #

COMET® Rounded Corner Guard (CG-2157A)

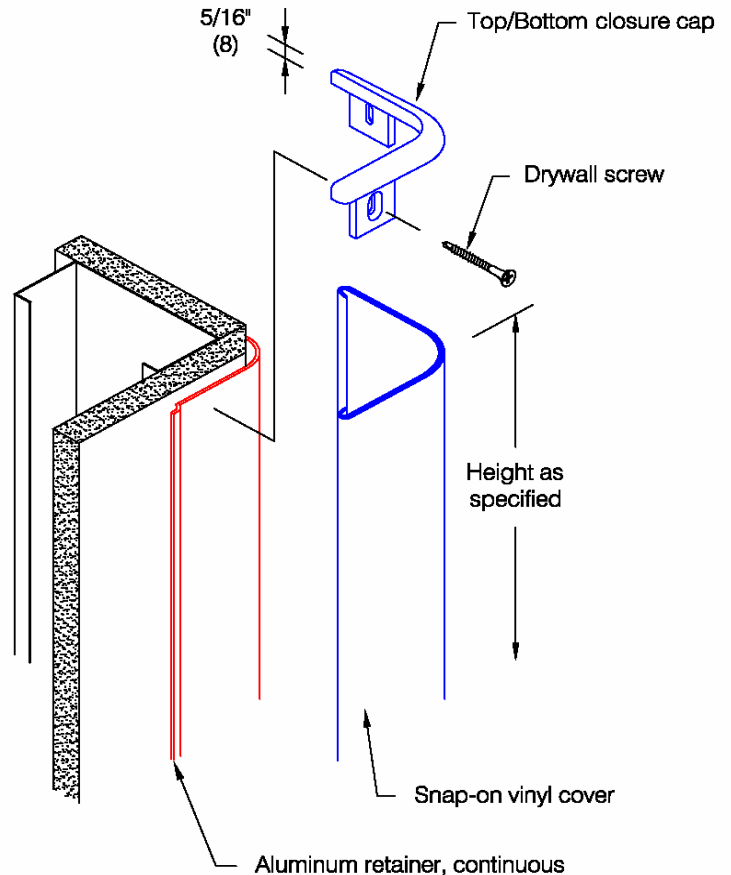
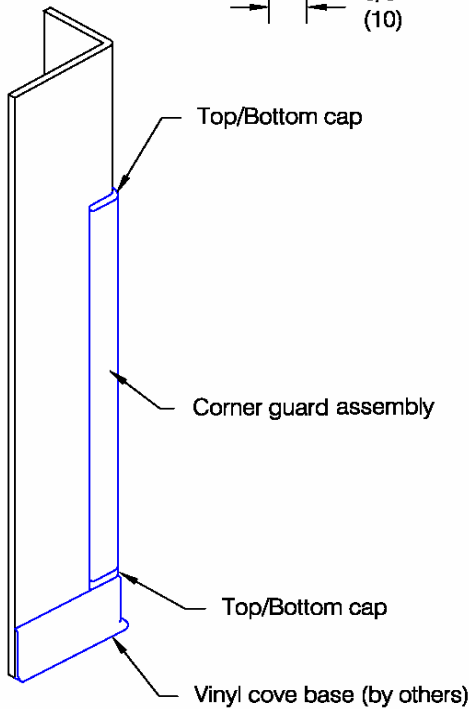
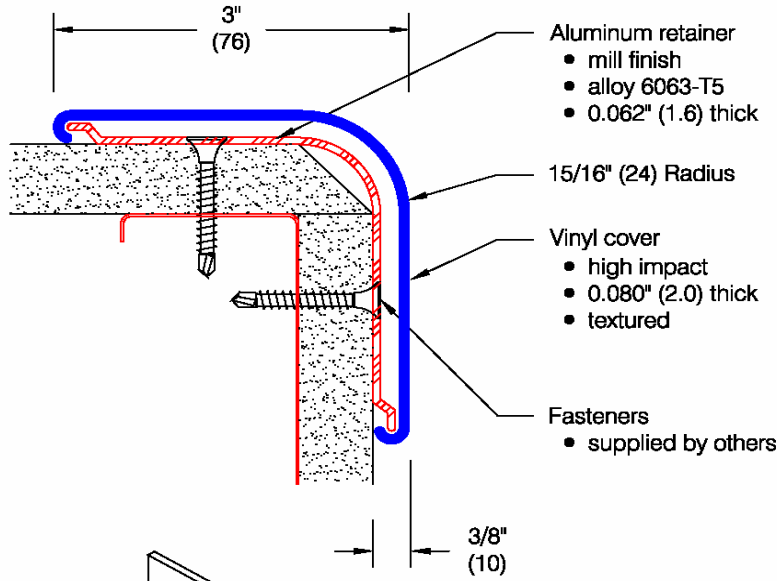

Application Diagram

*** Partial height installation with top and bottom caps shown. Full height installations may not require top or bottom cap.**

COMET® Rounded Corner Guard (CG-2157A)

Mounting	Application	Shock absorbing	Construction	Materials	Fire rating
Surface	High abuse	25.4 ft.lbs/in. ASTM D-256	New and renovation	Vinyl Aluminum	Class A

Testing in accordance with NFPA 255 (ASTM E 84):

Class A

Flame Spread Index: 5

Smoke Developed Index: 185

<p>Features:</p> <ul style="list-style-type: none"> • Class A fire rating • "Surface Mount" installation follows completion of drywall mounting • Stock lengths: <ul style="list-style-type: none"> 4'-0" (1219 mm), 8'-0" (2438 mm), 9'-0" (2743 mm), 10'-0" (3048 mm), 12'-0" (3658 mm) • Custom cut lengths available • Standard with textured top and bottom closure caps 	<p>Finishes:</p> <p>Vinyl cover (textured):</p> <ul style="list-style-type: none"> • Manufacturer's standard colors • Custom colors available <p>Aluminum retainer:</p> <ul style="list-style-type: none"> • Mill finish #405
---	---

Corner Guard designs conform to OSHA, ANSI Life Safety, NFPA, BOCA, UBC, BOMA, ICBO, SBCCI, American Disabilities Act Accessibility Guidelines and all National Building /Code requirements.

JOB NAME:	ITEMS	QUANTITY
JOB NUMBER:	Guard Length: 4', 8', 9', 10, 12'	
CONTRACTOR:	Color:	
ARCHITECT:	Top End Cap:	
DEALER NAME:	Bottom End Cap:	
SIGNATURE: _____	Date: _____	