



# AMERICAN FLOOR PRODUCTS COMPANY, INC.

**AFCO-USA**

P.O. BOX 7055 • Gaithersburg, Maryland 20898 -7055 • 301-987-0490 • Fax 301-987-0422

email: [sales@afco-usa.com](mailto:sales@afco-usa.com) • Web Site: [www.afco-usa.com](http://www.afco-usa.com)

## INSTALLATION INSTRUCTIONS

### Impact Protection Systems

### HANDRAILS: PRESIDENTIAL® (WG-2177)

#### Mounting Brackets: (Wall hardware by others)

1. Snap chalk line to ensure assembled rail will be at recommended height.
2. Drill appropriate size holes at recommended spacing for wall fasteners used.
3. Mount bracket and rail together by measuring and drilling aluminum retainer, inserting 1/4" bolts and washers through aluminum retainer, and through mounting bracket.
  - With standard toggle bolts, spin on toggle, and insert into wall.
  - If TOGGLER® brand is used, holes can be drilled along chalk line and toggler inserted in wall which eliminates spinning on toggle bolt; bolt can then be inserted through aluminum retainer and bracket directly into wall.
4. There should be a bracket placed within 6" of the end of each run.

#### Aluminum Rails:

Measure and cut aluminum rail, making appropriate allowance for returns, inside / outside corners.

**CAUTION:** Cut aluminum rail square to assure a neat joint when vinyl bumper cover is assembled and butted to returns and corners. Deburr aluminum ends of rails before assembly, which improves fit of cap and reduces chance of "nicks or scratches". Insert splices (if needed) on runs over 12 feet.

#### Returns and Inside Corners:

Should be attached to the aluminum rail with locknuts and flat washers (provided).

Always place a flat washer between locknut and vinyl tab and tighten with no more than 10 ft. lbs. of torque.

Mark, drill and fasten returns and inside corners to aluminum rail with fasteners, using care to insure return/corners are square with aluminum.

Deburr if necessary.

Check fit with a small 1" or 2" pieces of vinyl cover snapped into place. Fasten aluminum rail with returns and outside corners to wall, using mounting brackets and appropriate hardware.

#### NOTE:

1. Do not use lock washers.

Use flat washers only.

2. Apply 10 ft. lbs. of torque maximum.

#### Vinyl Covers:

Measure, cut and install vinyl cover 1/16" longer than required to improve fit. Remove any flash from cut with a deburring tool or small file.

#### NOTE:

Vinyl covers all require cutting with a mitre saw on both ends to insure proper fit to return and corner accessories.

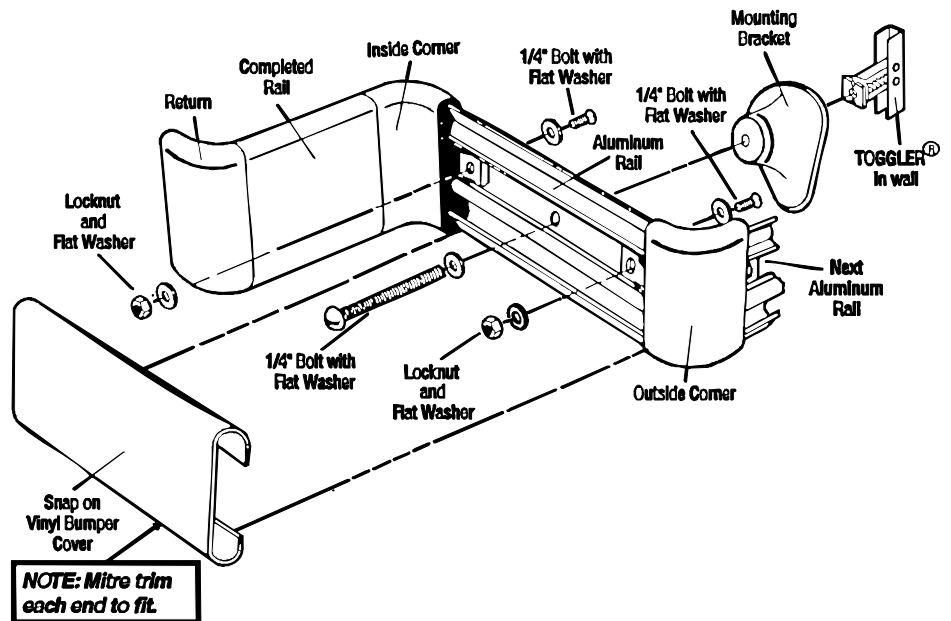

Rail Style	Wall Measurement Allowance for Return	Allowance for Outside Corners	Allowance for Inside Corners	Recommended Bracket Spacing	Recommended Rail Height
WG-2177	3-1/2"	5/16"	5-1/16"	32" (on studs)	31" - 33"

\*33" preferred - from University of Michigan Ergonomic Study.

Specifications subject to change without notice.