



# AMERICAN FLOOR PRODUCTS COMPANY, INC.

**AFCO-USA**

P.O. BOX 7055 • Gaithersburg, Maryland 20898 -7055 • 301-987-0490 • Fax 301-987-0422

email: [sales@afco-usa.com](mailto:sales@afco-usa.com) • Web Site: [www.afco-usa.com](http://www.afco-usa.com)

## INSTALLATION INSTRUCTIONS

### Impact Protection Systems

#### WALL GUARDS:

<b>SUNDANCE®</b>	<b>(WG-2101)</b>
<b>ARAWAK®</b>	<b>(WG-2106)</b>
<b>NAVAJO®</b>	<b>(WG-2169)</b>
<b>ZUNI®</b>	<b>(WG-2170)</b>
<b>APACHE®</b>	<b>(WG-2171)</b>
<b>INCA®</b>	<b>(WG-2175)</b>
<b>SHAWNEE®</b>	<b>(WG-2179)</b>
<b>AZTEC®</b>	<b>(WG-2180)</b>
<b>POWHATAN®</b>	<b>(WG-2181)</b>
<b>CHICKASAW®</b>	<b>(WG-2189)</b>
<b>IROQUOIS®</b>	<b>(WG-2197)</b>

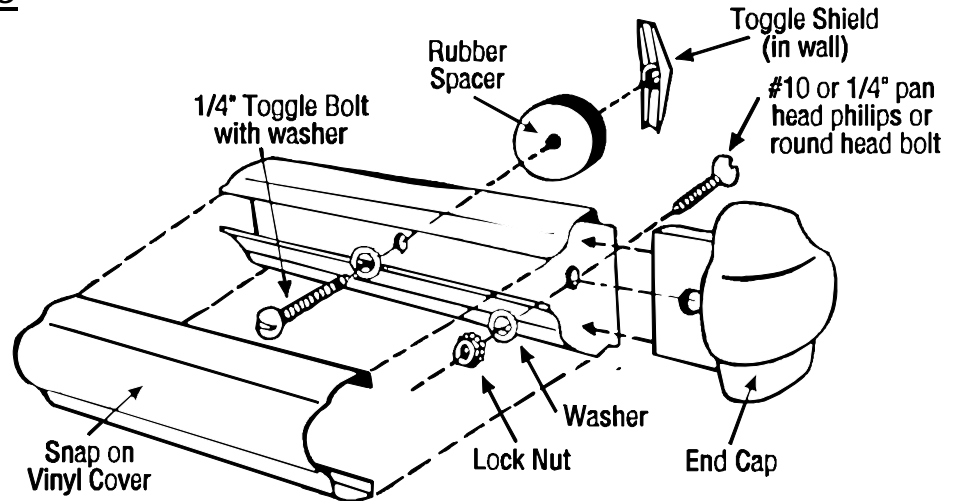

**Step 1:** Measure and cut the aluminum retainer, leaving the appropriate allowance for accessory parts. Deburr all aluminum and be sure the cut is square to insure proper alignment with the cap.

**Step 2:** Attach the aluminum retainer to the wall using the appropriate fastener.

**IMPORTANT:** First, drill holes with #27 size bit.

• **INTO A METAL STUD AND WALLS WITH HORIZONTAL BLOCKING OR PLATE BEHIND DRY WALL FOR FLUSH-TO-WALL INSTALLATIONS:**

Determine correct length of the slotted hex washer head self-tapping #10 or 1/4" screw based on layers of drywall.

When installing with a rubber spacer, use a 1/4" machine bolt with Toggler®.

• **INTO DRYWALL, WITH NO STUDS:**

1/4" Toggler® with machine screws, or Alligators®. When installed with a rubber spacer, longer screws are required. (See drawing on page 2).

**Step 3:** Attach end caps, outside and inside corners:

**IMPORTANT:** Pre-drill holes (see sizes below)

• **INTO DRYWALL WITHOUT A RUBBER SPACER (FLUSH TO WALL):**

1. Pre-drill holes in aluminum retainer to match existing holes in the accessory tabs. Use #27 bit for #10 fastener; use #7 bit for 1/4" fastener.

2. Fasten from the front with slotted hex washer head self-tapping #10 or 1/4" screw through the plastic flange of the accessory, and through the aluminum retainer. It is preferred that end caps only be installed with Alligator® fasteners or Toggler® bolts for added strength.

(See drawing on page 2).

• **INTO DRYWALL WITH A RUBBER SPACER:**

Mount the end cap to aluminum retainer before attaching to wall. Fasten from the rear with a #10 or 1/4" pan head philips or round head machine screw and lock nut with washer by drilling a clearance hole and inserting the bolt from the rear of the aluminum retainer and through the tab. (The washer and lock nut are then on top of the tab). (See drawing on page 2).

• **OUTSIDE CORNER INTO MASONRY WALL:**

1. Cut two 6" aluminum retainers.

2. Fasten the outside corner to the cut retainers from the rear with a #10 or 1/4" flat head philips machine screw and lock nut with washer by drilling, counter sinking and inserting the bolt from the rear of the aluminum retainer and through the tab.

(The washer and lock nut are then on top of the tab).

3. Drilling a pilot hole with a masonry bit and inserting Alligators® fasteners as recommended will prevent masonry corner from cracking or chipping. Drill minimum of 3" back from corner.

4. Continue installation of retainers per Step 2 options.

**NOTE:** No more than 10 lbs. of torque should be used when tightening accessory mounting hardware.

**Step 4:** Measure, cut and snap the rigid vinyl covers in place to complete the installation. Do not cut undersize. To assure a tight fit, deburr with a file.

**NOTE:** Vinyl covers all require cutting with a mitre saw on both ends to insure proper fit to return and corner accessories.

See more installation drawing details on page 2.



# AMERICAN FLOOR PRODUCTS COMPANY, INC.

**AFCO-USA**

P.O. BOX 7055 • Gaithersburg, Maryland 20898 -7055 • 301-987-0490 • Fax 301-987-0422

email: sales@afco-usa.com • Web Site: www.afco-usa.com

## DRYWALL INSTALLATION

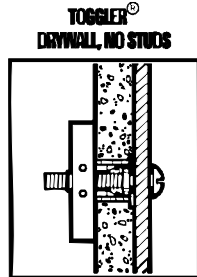

**Toggler®** is quick, easy fastener into drywall, no studs.

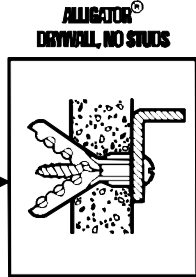

**Alligator®** is quick, easy fastener into drywall, no studs.

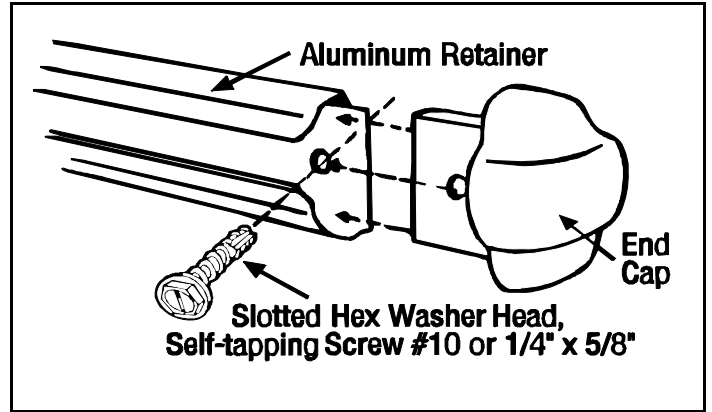

## MASONRY WALL INSTALLATION

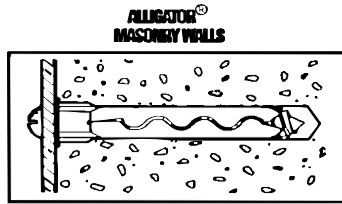

Suggested installation on masonry walls. See last item in description, Step 3 on the front.

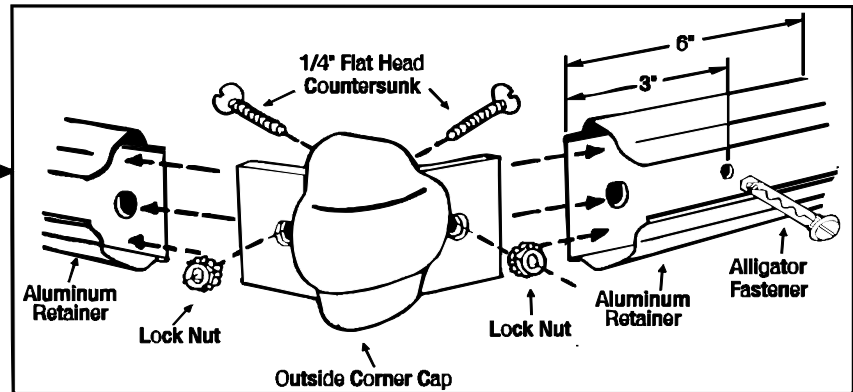

Wall Guard Style	Allowance* for each End Cap (Finished Assembly)	Allowance* for Outside Corners (Finished Assembly)	Allowance* for Inside Corners (Finished Assembly)
<b>PUEBLO®</b> (WG-2100)	1-3/8"	0	0
<b>SUNDANCE®</b> (WG-2101)	1-1/4"	0	0
<b>OTTAWA®</b> (WG-2102)	1-1/2"	5/16"	0
<b>ARAWAK®</b> (WG-2106)	1-1/8"	5/16"	0
<b>NAVAJO®</b> (WG-2169)	1-1/8"	0	0
<b>ZUNI®</b> (WG-2170)	1-5/8"	0	0
<b>APACHE®</b> (WG-2171)	2-1/2"	0	0
<b>INCA®</b> (WG-2175)	1-1/16"	0	0
<b>SHAWNEE®</b> (WG-2179)	1-1/8"	0	0
<b>AZTEC®</b> (WG-2180)	1-13/16"	0	0
<b>POWHATAN®</b> (WG-2181)	1-1/8"	0	0
<b>CHICKASAW®</b> (WG-2189)	13/16"	0	0
<b>YUMA®</b> (WG-2196)	1"	1-5/8"	1"
<b>IROQUOIS®</b> (WG-2197)	1-7/8"	0	0

\*A tolerance of + 1/16" - 1/8" is built in for end caps.

Specifications subject to change without notice.